

## Paralleling & Redundancy..... Understanding the Differences

Some power supplies are marked parallel capable which allows the unit to be connected in parallel with no immediate harm, but it does not automatically mean that the unit has the capability of load sharing. Load sharing balances the total load between two or more supplies connected in parallel, and can actually prolong the life of a supply as the units may not operate at full capacity. Please check the manufacturer's data sheet to ensure that the specific power supply is intended for paralleling, otherwise irreparable damage could occur.

### Basic Paralleling:

Let's begin by explaining what occurs when two power supplies are connected in parallel, but do not have load sharing capabilities. Because of drift and other factors, it is impossible to have both supplies set with the exact output voltage. The unit that has the higher output voltage will become the lead supply and will carry the entire load current. If the switching power supply used follows a typical fold-forward curve, the output voltage will start to drop once the unit has exceeded its rated current. Once the output voltage has dropped enough to match the second supply, the other unit will start to carry current.

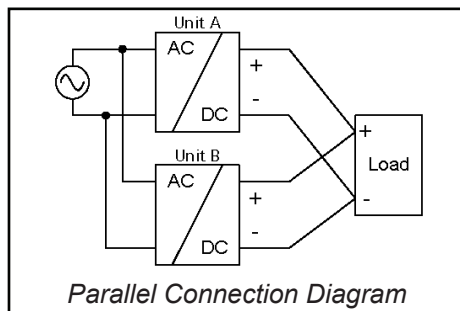

Parallel Connection Diagram

Typically, the first supply is running in an overload condition and can lead to premature failure due to excess heat. The general rule for power supplies is that every 10°C increase in temperature surrounding the supply reduces the life of the product by half.

### Enhanced Paralleling:

On the other hand, using two supplies that have load sharing capabilities delivers a different result because the supplies are designed with an additional internal feedback circuit. This method is called passive load sharing. The same situation will occur as in the first example with one unit having a slightly higher output voltage. However, because of the feedback circuit, the supply can sense that too much current is being delivered too quickly and internally tapers back the output voltage. The lag supply is initially carrying no current because the output voltage is lower than the lead supply, so the feedback circuit mechanism increases the output voltage. This back and forth adjustment between the two power supplies occurs internally very rapidly, but does not affect the output voltage supplying the load. This rapid adjustment is what helps balance the current between the two supplies, but the current supplied by each unit is never 100% equal. The PULS Q-Series supplies are microprocessor controlled, so paralleling is handled differently but just as efficiently. These units do not load share in the traditional sense, but the microprocessor ensures that the lead unit only carries the rated current before handing off the remaining load to the other power supply unit(s).

### Paralleling Considerations:

The difference in output voltages of each supply also determines how much balance occurs, and therefore the voltages should be set as close as possible to each other. Because each manufacturer's output circuit is designed differently, the use of the same brand of power supply is recommended when connecting in parallel. The same design can react appropriately to the rapid adjustments or current distribution whereas unforeseen problems can occur when two different brand supplies are used together. It is also recommended that supplies in the same family are used when paralleling. Another factor to consider when connecting in parallel is that power supplies should be mounted side-by-side. Placing one unit above the other can cause excess heating of the top unit as heat rises from the lower. Also consider using a distribution block for the load wires to prevent possible over-heating of the supply terminals and to keep the wire lengths the same, avoiding voltage drops which affects the load sharing.

### Redundancy:

Redundancy is the doubling up of critical components in order to increase the reliability of a power supply system and ensure that if one unit fails the remaining units will carry the load. Redundancy utilizes the same techniques as in paralleling; however, additional protection concepts are added. Care needs to be taken so that a failed or de-energized unit does not become a burden on the remaining equipment, which is accomplished with de-coupling diodes. Two power supplies connected in

parallel offer a certain degree of redundancy, but in order to be fail-safe, a de-coupling diode for each supply should be incorporated into the design.

### Types of Redundancy:

There are several types of redundancy systems. The most typical is called 1+1 redundancy where only one power supply is needed to handle the load, but an extra one is installed in case one fails. For N+1 redundancy, N represents how many power supplies it would take to operate the load, and then a spare is added in case one stops functioning. For example, if the load was 20A and you wanted to use a 10A supply, it would take two units to operate the load, but the third is added as the spare. In this application, any one unit can be removed and the remaining supplies will operate the load. There are additional redundant applications, but the two mentioned here are the most common. PULS offers true single phase redundancy power supplies with the de-coupling diodes already built in. PULS also offers many single and three phase supplies that are allowed to be paralleled. Using these supplies along with one of many PULS de-coupling

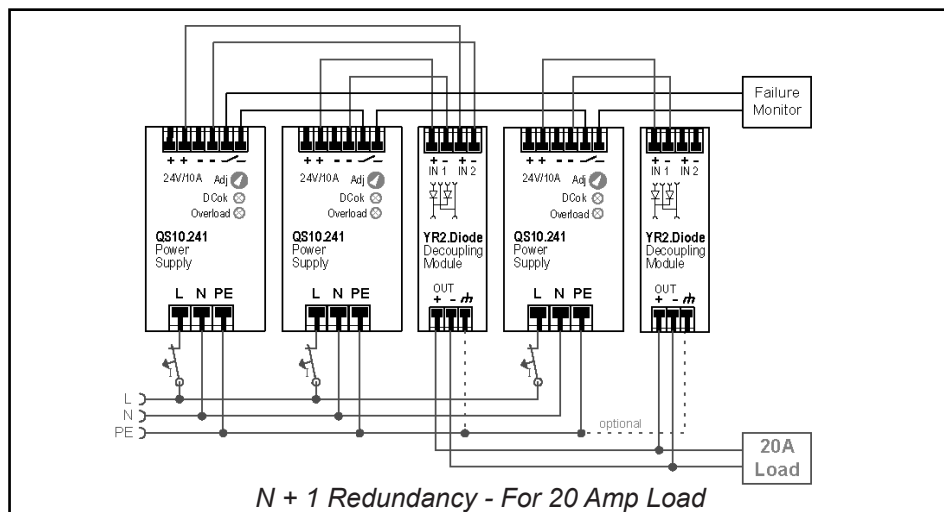

(redundancy) modules allows for a modular, flexible redundant system.

### Rules for Redundancy:

Many of the same rules apply for redundancy as for paralleling, but there are a few more considerations. N+1 redundancy should use power supplies designed for paralleling as multiple units carry the load. However, 1+1 redundancy typically allows non-parallelable supplies to be used because any single unit is never overloaded. Each power supply should be connected to a different AC source, because if all the units were

connected to one source and that source failed, all the power supplies would stop working, defeating the purpose of a redundant system. However, this separate feed is not always possible in a control panel. A redundant system should also provide a way to monitor the power supplies. The external signal is used to inform a PLC, alarm or personnel that there is a problem with one of the supplies. This is important because a redundant system is only good if it informs you when power supplies are not working correctly.

### Advantages of Redundancy:

Redundancy is used primarily when down time is not acceptable, or when the cost of the extra power supplies far out-ways the cost of the down time. The benefits of using standard off the shelf components to build your redundant system are easy to see, and as your system grows you have the flexibility to add more supplies without the need of rewiring your whole control system. PULS offers a wide variety of products to meet all of your paralleling and redundancy needs.

