

“Single Battery Concept” for 24VDC UPS Systems

UPS applications are becoming more popular as power problems increase and the cost of down time becomes more expensive. With more and more control panels switching to DC, design engineers are moving the backup from the AC side to the DC side. Traditional 24VDC UPS systems utilize two 12V batteries in series which provides the power needed when the AC fails. However, this approach has several disadvantages.

Two Batteries in Series:

With just a series connection, it is only possible to measure the sum of the battery voltage and not the individual batteries. The batteries when fully charged could have an output voltage higher than 27VDC. When running on battery, the output voltage to the load follows the battery voltage and depending on the time that the load is running on the batteries, the voltage can continue to decay well below 19VDC. Depending on the sensitivity of the device connected, the under voltage could cause the load to drop out. With two batteries in series, it is recommended to use only matched batteries from the same manufacturing

lot so that the characteristics are the same. Mismatched batteries can cause uneven charging resulting in a higher voltage on one battery and a lower voltage on the other. The battery with the higher voltage could see an overcharge and the battery with the

At higher ambient temperatures, the higher battery voltage can also increase dangerous hydrogen out gassing.

Single Battery:

Several years ago after extensive

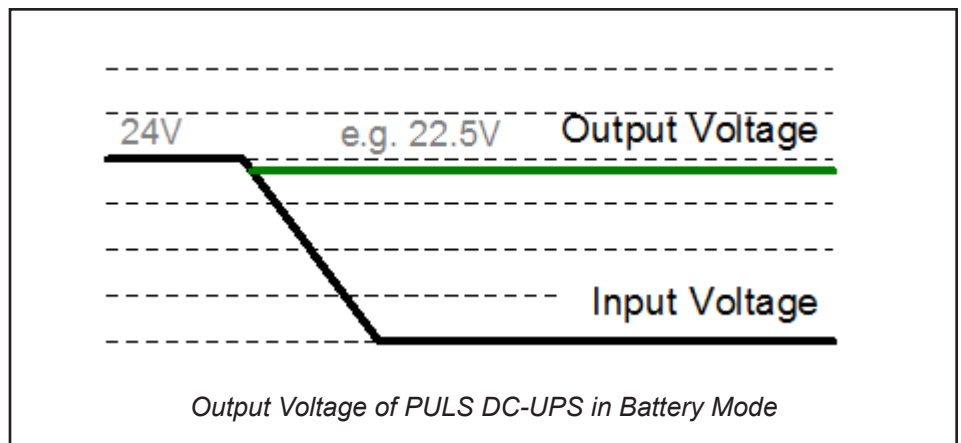

lower voltage may not fully charge resulting in a shortened battery time. Overcharging can dramatically reduce the lifetime of a battery. An overcharge of just 0.1V per cell can shorten the battery life by 50%. Also, the added heat increases the aging effect resulting in a loss of capacity and an even greater voltage differential.

research, PULS introduced a line of 240W, 10A, 24VDC UPS controllers that only require a single 12V battery to back up a 24VDC load. This unique and innovative approach took the market by surprise but has many distinctive advantages over using two batteries in series. Since there is only one 12V battery, the issue of mismatched batteries is no longer a concern which allows a more precise battery charging. Superior battery management leads to a longer battery life and can lower maintenance costs by replacing fewer batteries. A step-up converter amplifies the 12V from the single battery to a fixed regulated output voltage which is independent of the battery voltage. Constant output voltage during the entire battery event allows applications to run without problems due to no voltage drops. A single battery allows for better battery

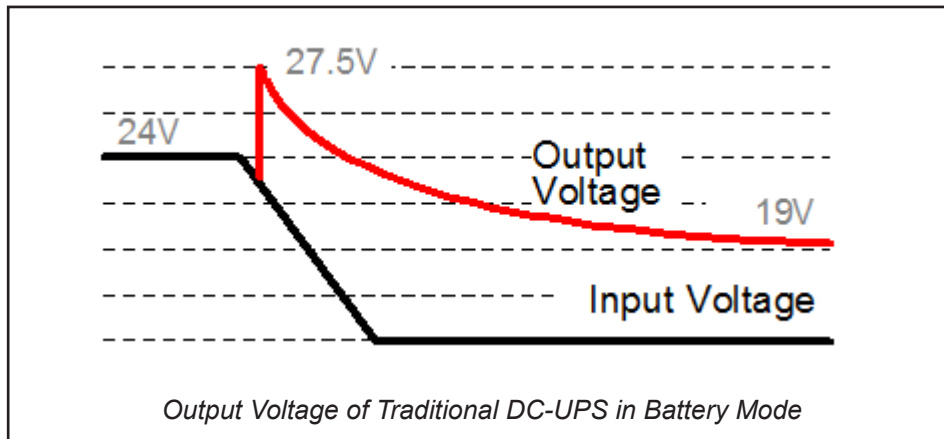

The PULS Advantage

Issue 17

diagnostics as only one battery voltage is being maintained and monitored. The single battery also allows precise battery tests to occur during operation and can remotely signal when it is time to replace the battery. The PULS UPS controllers have a distinct relay contact dedicated to the "Replace Battery" signal where other manufacturers have just a general alarm. This feature can provide a better indication of when the battery needs to be replaced, instead of a random maintenance program where batteries that are still functional are replaced because there is no easy way to measure the battery "State of Health".

Single Battery Concept with Two Batteries Connected in Series:

PULS recently introduced a 480W, 20A, 24VDC UPS controller. With a higher output current, the concern during the design phase was what impact a single battery would have on the battery current and the power losses between the battery and the UPS controller. A 20A load could have a battery current as high as 50A which would require large battery cables. In order to reduce the battery current, PULS elected to utilize two batteries in series while developing a method to maintain the "Single Battery Concept". By center tapping the pair of batteries,

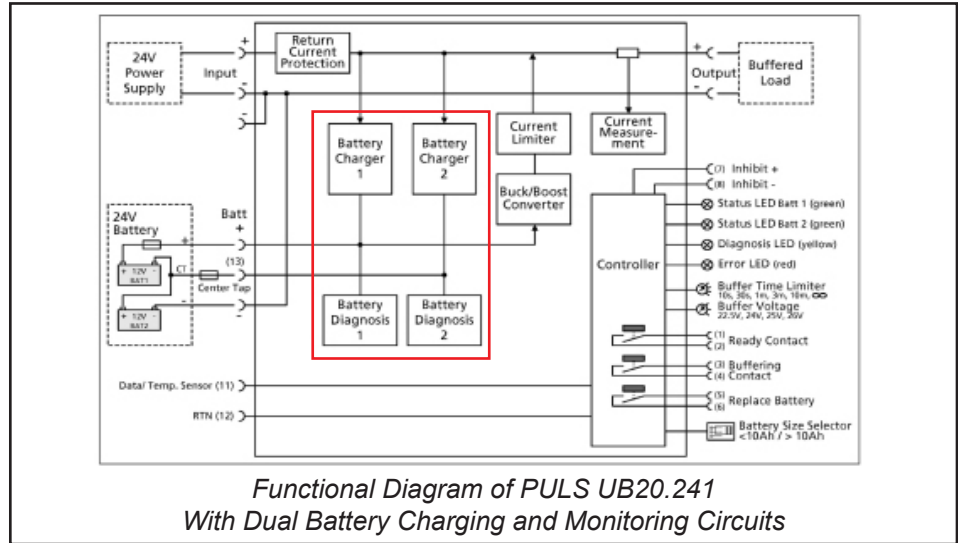

each battery can be independently charged and monitored while still providing a fixed regulated output voltage to the load regardless of the battery voltage levels. Maintaining the "Single Battery Concept" despite the use of two batteries, allows the PULS 20A DC UPS to provide the same advantages associated with the PULS 10A DC UPS series has offered for the past several years. The center tap also allows for mismatched batteries to be used as each battery is charged independently of the other. In addition to each battery being charged, the PULS 20A DC UPS has provisions for a PT1000 temperature sensor, allowing for an even more precise

end of charge battery voltage. This UPS controller can provide a means of replacing the traditional two battery UPS in the field, while providing all the benefits of a single battery.

The PULS Advantage:

The unique "Single Battery Concept" whether using one battery or two, allows for a precise battery management providing the longest possible battery life while delivering a fixed regulated output voltage during the entire discharge of the battery. This concept also allows accurate monitoring of the battery and can provide a signal when it is time to replace the battery.

PULS DC-UPS with "Single Battery Concept"

Catalog Number	Output Voltage	Output Current	Battery
UB10.245	12VDC / 24VDC	5A / 7.5A	Single External 3.9 - 40Ah
UB10.241	24VDC	10A	Single External 3.9 - 40Ah
UB10.242			Single External 17 - 130Ah
UBC10.241			Single Internal 5Ah
UB20.241	24-26 (Selectable)	20A	Two External 3.9 - 150Ah